

Date: \_\_\_\_\_ Location: \_\_\_\_\_  
Product: \_\_\_\_\_ Project: \_\_\_\_\_  
Quantity: \_\_\_\_\_ Catalog #: \_\_\_\_\_

## LED Barn Light (Dusk to Dawn) Series



### FEATURES

- Adjustable Wattage: 35W, 50W & 65W
- Adjustable CCT: 3,000K, 4,000K & 5,000K
- ON / OFF Photocell switch
- IP66 rated
- Corrosion resistant
- 50,000 hours lifetime

### SUITABLE APPLICATIONS

- Commercial buildings
- Schools
- Barns
- Yards & Loading Docks
- Streets

### CONSTRUCTION:

Cold forged aluminum housing with PC lens

### OPTICAL SYSTEM:

SMD 2835 LED chips. 140° beam

### WARRANTY:

5-year limited warranty. Actual performance may differ as a result of end-user environment and application.

### ELECTRICAL:

Available as 120-277V input. -40°C to 45°C

### INSTALLATION & MOUNTING:

Wall Mount or Arm Mount

Minimum Pole Size: 1.48"

Maximum Pole Size: 16.1"



MODEL NUMBER	WATTAGE	LUMENS	EFFICACY	CRI	POWER FACTOR	THD
LOC-BL-MW(35/50/65)MCCT(30/40/50)	35W	4,396.7LM	125.62LM/W	72.1	0.8923	18.86%
LOC-BL-MW(35/50/65)MCCT(30/40/50)	50W	6,281LM	125.62LM/W	72.1	0.8923	18.86%
LOC-BL-MW(35/50/65)MCCT(30/40/50)	65W	8,074.6LM	125.62LM/W	72.1	0.8923	18.86%

# MEASUREMENTS

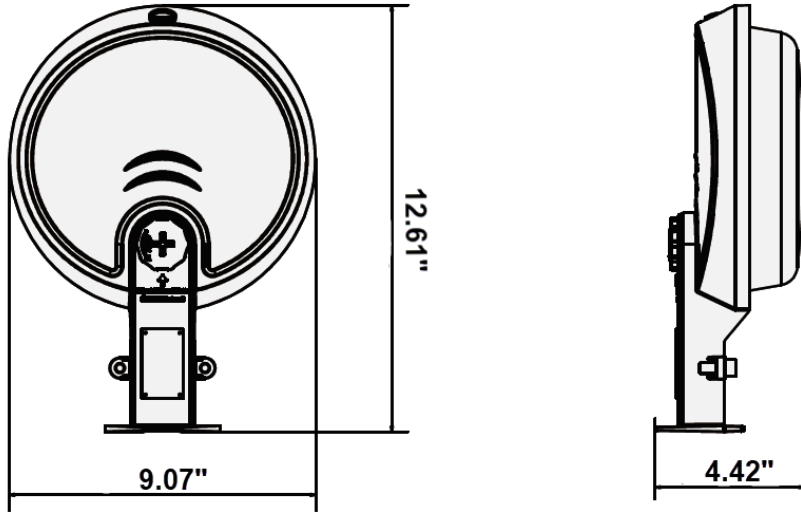

QUANTITY	WEIGHT
1	3.31 lbs

# OPTIONAL ACCESSORIES



Arm Mount



# PHOTOMETRIC DATA

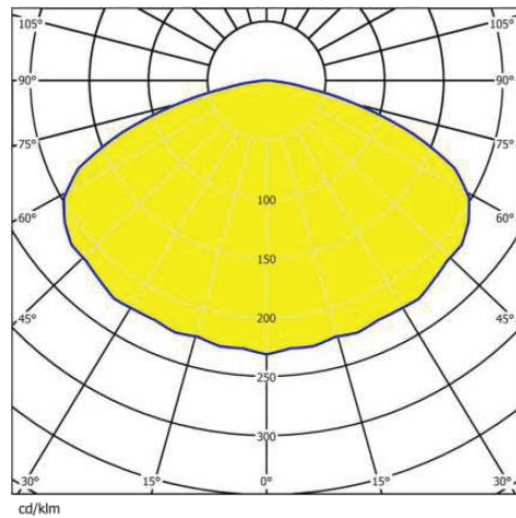

140°