

PRODUCT DESCRIPTION:

No ballast required. Disconnect or remove the ballast before installation. Mainly used in garages or warehouse lighting.

FEATURES:

- Samsung 2835 LED chips
- IP42 rated
- Suitable for enclosed fixtures
- Non-dim
- No fans for moving parts providing outstanding reliability
- Surge protection 4KV

DIMENSIONS:

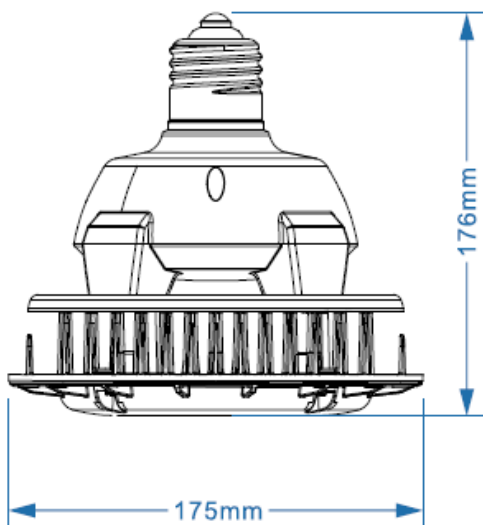

Low Bay 60W Spec

LOD-LB60W-50K



SPECIFICATIONS:

SPECIFICATION	Details
Model	LOD-LB60W-50K
Input Wattage (W)	60W
Lumens Delivered (LM)	6,307.6LM
Efficacy (LM/W)	107LM/W
CRI	83
Lifespan	50,000 hours
Color Temperature	5,000K
Wattage Equivalent	200W HPS/MHL
Dimmable	No
IP Rating	IP42
Beam Angle	220
Input Voltage	AC100-277V
Power Factor	0.91
Housing	Aluminum
Lens	Clear
Mounting	E39 base
Size	6.92" x 6.88"
Weight	2.14 lbs
THD	17.2%
Certification	DLC, UL
Operating Temperature	-40°C to 60°C
Environment	Indoor
Warranty	5 years limited



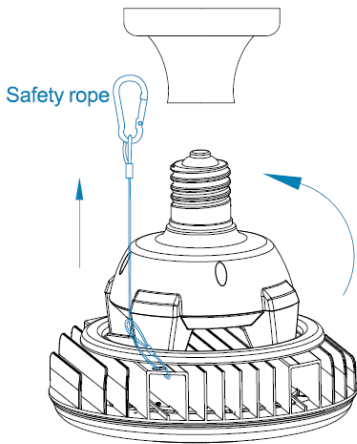

Step:1

Shown as Figure 1
Turn off the power before installation.

Remove the old ballast, capacitor and ignitor(if existing)

Step:2

Shown as Figure 2
Make sure the alternating Current Wires connect to the E26, E39 or EX39 socket directly (Reattach or replace ground lead if one is needed)

Step:3

Shown as Figure 3
Screw the LED lamp onto the corresponding socket.

