

## PRODUCT DESCRIPTION:

The linear high bay is the lighting solution for a wide variety of applications and mounting heights. A choice of lumen outputs and color temperatures make the high efficacy the ideal solution for industrial, commercial and other high bay application.

## FEATURES:

- PMMA material
- Samsung 2835 LED chips
- Steel and aluminum body
- High quality LED chips with 100,000 hours
- 0-10V dimming available

## LED Linear High Bay Spec

LOD-LHB160W-40K

LOD-LHB160W-50K



## DIMENSIONS:

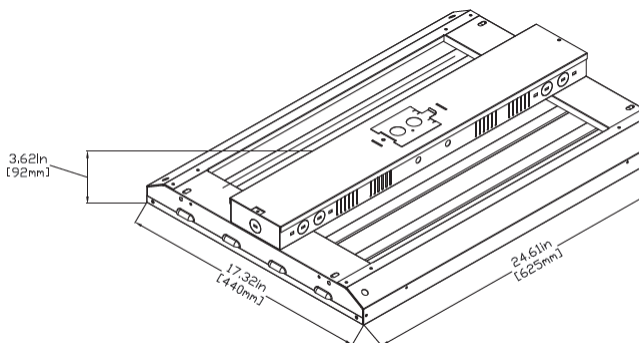

## SPECIFICATIONS:

SPECIFICATION	Details	
Model	LOD-LHB160W-40K	LOD-LHB160W-50K
Input Wattage (W)	160W	
Lumens Delivered (LM)	21,977LM	22,025LM
Efficacy (LM/W)	136.5LM/W	136.8LM/W
CRI	80	80
Lifespan	100,000 hours	
Color Temperature	4,000K	5,000K
Wattage Equivalent	400W	
Dimmable	Yes	
IP Rating	IP54	
Beam Angle	120	
Input Voltage	AC120-277V	
Power Factor	0.9	0.9
Housing	Steel & Aluminum	
Lens	Frosted	
Mounting	Hanging Chain	
Weight (LBS)		
THD	20%	20%
Size (inches)	24.61" x 17.32" x 3.62"	
Certification	DLC, UL	
Operating Temperature	-20°C-40°C	
Environment	Indoor	
Warranty	5 years limited	

4000K is a special-order request

